

EH222 – 600-1000 lb Cube Ice Machine

Prodigy™ Eclipse® Remote Cooled Modular Cube Ice Maker



EH222 shown on ice dispenser.



Compressor Unit



Remote Condenser

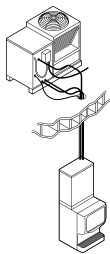

Eclipse System connected to single remote condenser.

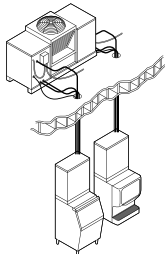

Two Eclipse Systems connected to a dual remote condenser.

Features

Equipped with Prodigy™ self-monitoring technology **Auto-Alert™ indicator lights**, patented **WaterSense** adaptive purge control as well as Prodigy's superior cost-saving energy efficiency.

Eclipse® technology moves the compressor and condenser to the roof, moving noise and heat away from customers & workers, resulting in a quieter environment.

The small footprint and narrow profile offer the **ability to place the ice machine where ice is needed**, at the drive through window or in the dining room at a self-service beverage station.

Flexible design allows Eclipse® ice machines to be paired with a wide variety of dispensers or storage bins, supplying ice to any area of your operation.

Offers **quick and flexible installation** because it can be connected to either a single remote condenser, dual remote condenser or properly sized universal rack or multi-pass condenser system.

24 Hour Volume Production

EH222 600 lb			EH222 800 lb			EH222 1000 lb		
70°F/21°C 50°F/10°C lb/kg	Air Water	ARI 90°F/32°C 70°F/21°C lb/kg	70°F/21°C 50°F/10°C lb/kg	Air Water	ARI 90°F/32°C 70°F/21°C lb/kg	70°F/21°C 50°F/10°C lb/kg	Air Water	ARI 90°F/32°C 70°F/21°C lb/kg
700/318		550/250	855/389	700/318		1035/470		882/401

Modular Dispenser & Bin Options

Model Number*	Dimensions W" x D" x H"	ARI Certified Bin Capacity lb/kg	Application Capacity lb/kg	Finish	Ship Weight lb/kg
ID150/ABS	22 x 30 x 35	-	150/68	SS	150/68
ID200	30 x 30 x 35	-	200/91	SS	200/91
ID250	30 x 30 x 39	-	250/114	SS	300/136
B322S	22 x 34 x 44	290/132	370/168	SS	140/64
BH1100BB	48 x 34 x 50	860/393	1100/499	SS w/ GBB**	280/127
BH1100SS	48 x 34 x 50	860/393	1100/499	SS	280/127

* See Scotsman Price List for Required Bin Tops.

** Stainless Steel with Galvanized Back & Bottom.



Cube Ice



Small Cube
7/8" x 7/8" x 3/8"
(2.22 x 2.22 x .95 cm)



Medium Cube
7/8" x 7/8" x 7/8"
(2.22 x 2.22 x 2.22 cm)

Common ice form, ideal for mixed drinks.

Warranty

- 3 years parts and labor on all components.
- 5 years parts and labor on the evaporator.
- 5 years parts on the compressor and condenser.

Warranty valid in North, South & Central America. Contact factory for warranty in other regions.

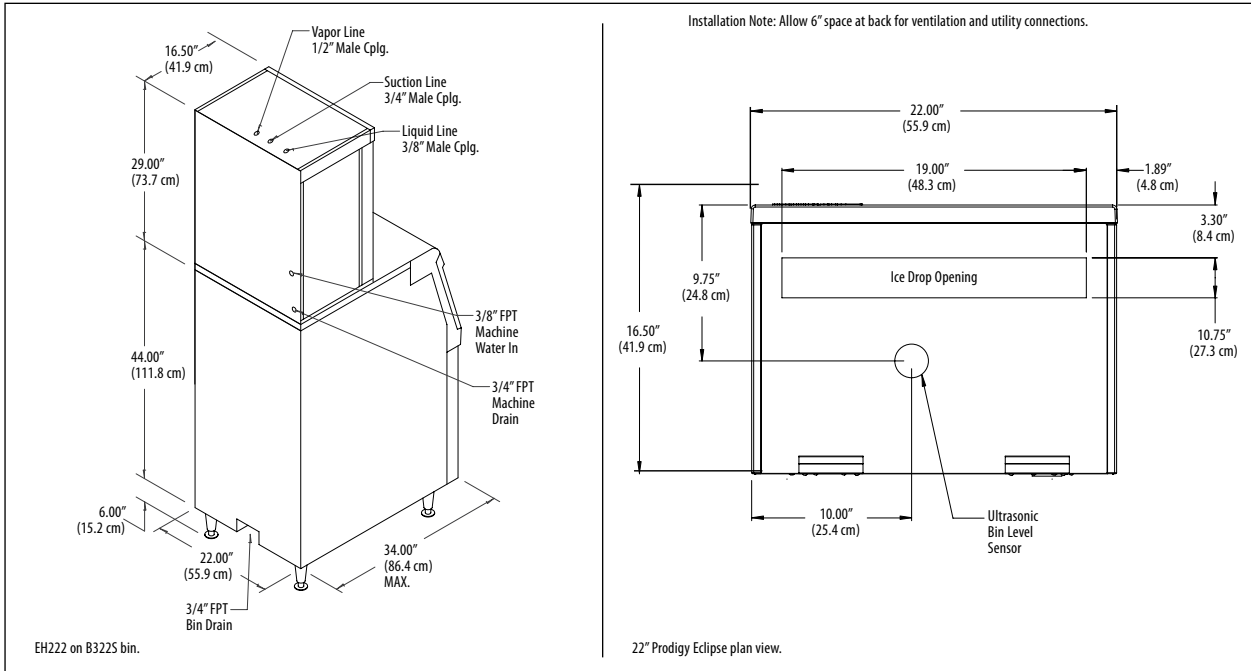

Specifications

Model Number	Compressor Unit	Basic Electrical Volts/Hz/Phase	Max. Fuse Size or HACR Circuit Breaker (amps)	Circuit Wires	Min. Circuit Ampacity	Energy Consumption kWh/100 lb (45.4 kg) 90°F(32°C)/70°F(21°C)	Water Usage Gallons/100 lb (liters/45.4 kg)	
							Potable 90°F(32°C)/70°F(21°C)	Condenser 90°F(32°C)/70°F(21°C)
EH222SL-1A	-	115/60/1	15	2	Cord	-	-	-
EH222ML-1A	-	115/60/1	15	2	Cord	-	-	-
	C0600CP-32A [*]	208-230/60/1	15	2	10.0	6.7	18.5/70.0	-
	C0800CP-32A ^{**}	208-230/60/1	20	2	14.8	5.5	18.0/68.2	-
	C1410CP-32A ^{***}	208-230/60/1	30	2	16.5	5.1	18.0/68.2	-
	C0800CP-3A ^{**}	208-230/60/3	15	3	10.6	5.5	18.0/68.2	-
	C1410CP-3A ^{***}	208-230/60/3	20	3	12.6	5.1	18.0/68.2	-

^{*}Use for EH222 600 lb. (SL-1A only) ^{**}Use for EH222 800 lb. ^{***}Use for EH222 1000 lb.

All Models

Dimensions (W x D x H):
 EH222 Unit: 22" x 16.5" x 29"
 (55.9 x 41.9 x 73.7 cm)
 Shipping Carton: 25.5" x 19.5" x 34"
 (67.8 x 49.5 x 86.3 cm)
 Compressor Unit: 30" x 18" x 35"
 (76.2 x 45.7 x 88.9 cm)
 Shipping Carton: 33" x 21" x 38"
 (83.8 x 53.3 x 96.5 cm)
 Shipping Weight: EH222 110 lb. / 50 kg.
 C0600CP 200 lb. / 92 kg.
 C0800CP 215 lb. / 98 kg.
 C1410CP 225 lb. / 102 kg.
 BTUs per hour: 8,200^{*}/13,700^{**}/20,000^{***}

^{*}Use for EH222 600 lb. ^{**}Use for EH222 800 lb. ^{***}Use for EH222 1000 lb.

Accessories

Model Number	Description
KVS ⁽¹⁾	Vari-Smart™ Ice Level Control - Program ice bin levels to match ice needs.
KSB	Smart-Board™ Advanced Control - Use additional operational data for fast diagnosis.
KSB-N	Smart-Board™ Advanced Control with Network - Network capable.
ERC680-32A	Remote Condenser for Eclipse 0600-0800 lb., 208-230/60/1
ERC1086-32A	Remote Condenser for Eclipse 1000-1400 lb., 208-230/60/1
ER2C6810-32A	Remote Condenser for Eclipse two 600/800/1000 lb., 208-230/60/1
3RTE20-EH	Line set, Precharged, R-404A, 20ft.
3RTE35-EH	Line set, Precharged, R-404A, 35ft.
3RTE50-EH	Line set, Precharged, R-404A, 50ft.
3RTE75-EH	Line set, Precharged, R-404A, 75ft.

(1) KVS included standard on EH222. Scotsman recommends all ice machines have water filtration. See Scotsman Sanitation Matrix for details.

Operating Requirements

	Minimum	Maximum
Air Temperatures	50°F (10°C)	100°F (38°C)
Water Temperatures	40°F (4.4°C)	100°F (38°C)
Remote Cond. Temps	-20°F (-29°C)	120°F (49°C)
Water Pressures	20 PSIG (1.4 bar)	80 PSIG (5.5 bar)
Electrical Voltage	-5%	+10%